



Yuasa Scheda Tecnica

Yuasa M27-90S - Batterie Marine

Prestazione

Tensione	12V
Capacità (20 ore)	90Ah
Corrente di spunto A (EN1)	720A

Dimensioni

Lunghezza	304mm
Profondità	173mm
Altezza	225mm

Pesi e Misure

Peso medio con acido	21.2kg
----------------------	--------



Caratteristiche del Monoblocco

Tipo di monoblocco	GR27 BCI
Schema polarità	1
Fissaggi alla base	B1
Indicatore dello stato di carica	✓
Maniglie	✓
Circuito di sfiato	✓
Applicazioni da semi trazione	✓
Tipo di coperchio	Doppio Coperchio SMF

Tecnologia

Pastiglia antideflagrante	✓
Tecnologia	Ca/Ca
Separatore	PE
Corrente di carica raccomandata	5A

Tipologia dei terminali

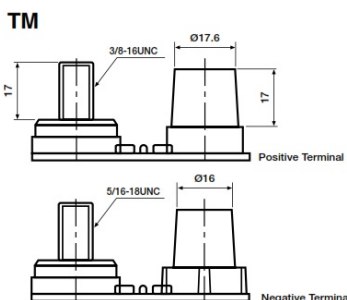

Schema di Collegamento

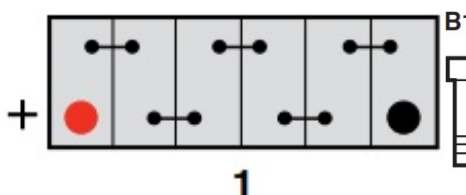

Fissaggio batteria

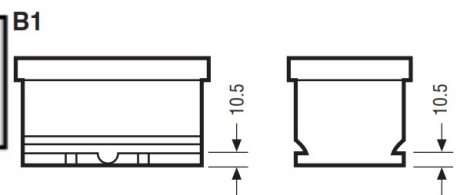

Scheda tecnica prodotta su E&OE



Yuasa Technical Data Sheet

Yuasa M27-90S - Marine Batteries

Performance

Voltage	12V
Capacity (20-hour)	90Ah
Cold Cranking Amps (EN1)	720A

Dimensions

Length	304mm
Width	173mm
Height	225mm

Weights & Measures

Mean Weight with Acid	21.2kg
-----------------------	--------

Container Features

Case Type	GR27 BCI
Cell Layout	1
Hold Down	B1
State of Charge Indicator	✓
Handles	✓
End Venting	✓
Semi-Traction Features	✓
Lid Type	SMF Double Lid

Technology

Flame Arrestor	✓
Technology	Ca/Ca
Separator	PE
Recommended Charge Rate	5A

Terminal Type

Cell Assembly Layout

Battery Hold-down

Data Sheet generated on 15/04/2021 – E&OE